

SCALE 1:1

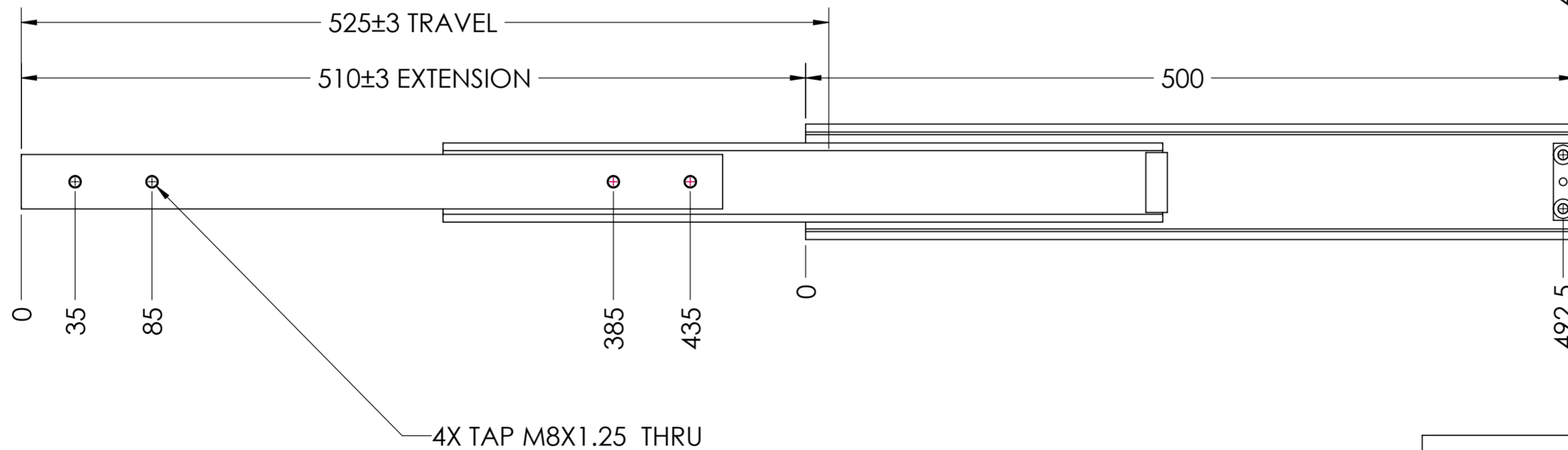
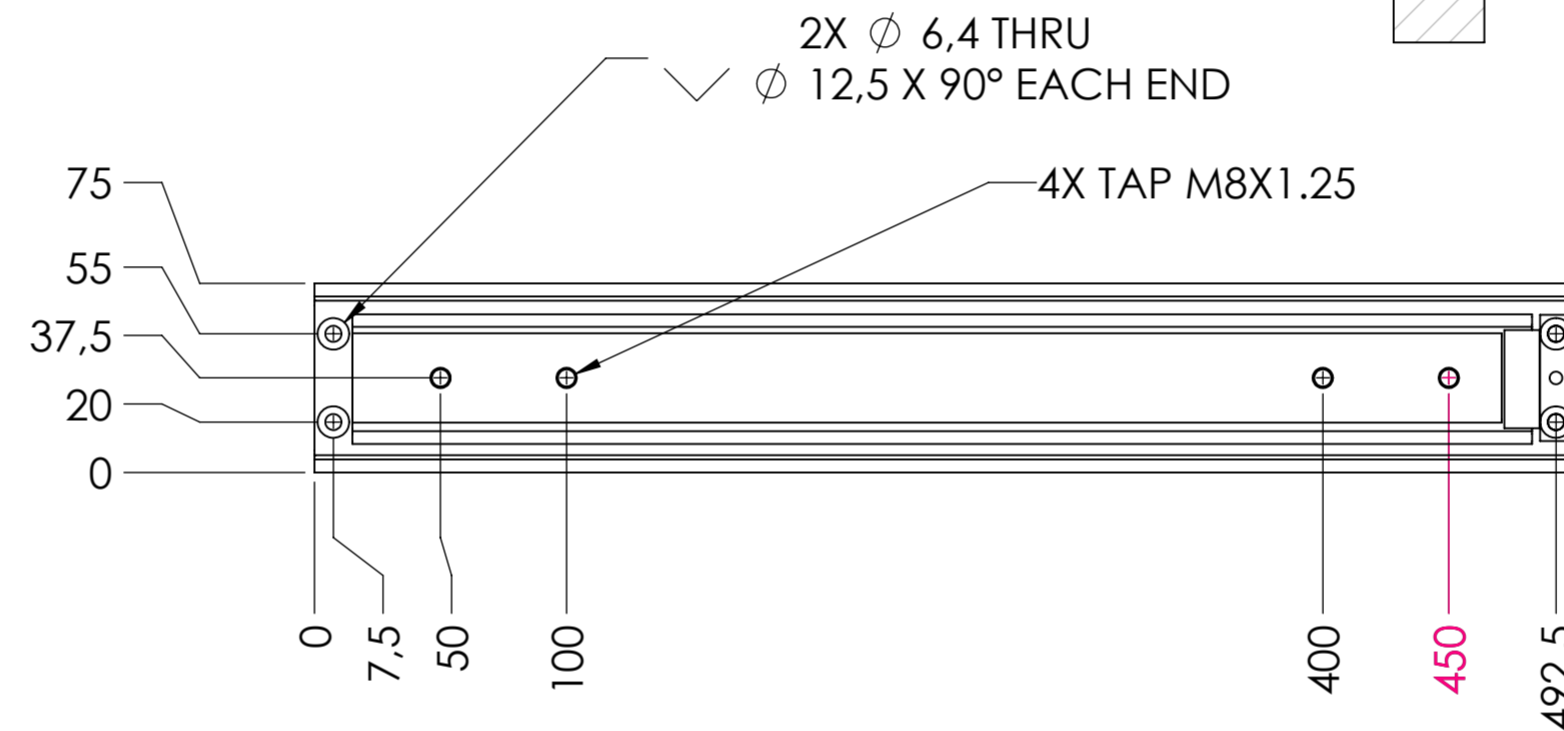

RECOMMENDED HARDWARE:
CABINET- M6 FLATHEAD SCREWS

DRAWER- M8x1.25 SCREWS

general tolerances		DIN ISO 128-30 missing dimensions see 3D = theor. intersection	
ISO 2768-m			
This drawing remains our property and may not be multiplied neither be disclosed to third parties (§§1,3 and 5 from the copyright Act (UrhG)) covered according to DIN ISO 16016			
(k)		scale:	surface:
(l)		1:3	
(i)		date	name
(h)		drawn 20-07-2018	HB
(g)		proven 00-00-0000	00
(f)		Fulterer	
(e)			
(d)		Fulterer AG & Co KG	
(c)		A-6890 Lustenau / Austria	
(b)		Fulterer AG	
(a)	0	00-00-0000	0
ind.	changes	date	na.
		drawing number: 5426.500-GA.T092	
		replaces version date:	